

LIFTS



HYDRAULIC TWO-POST LIFT

JLT3500 with exclusive Versymmetric® technology, providing the versatility to lift both symmetrically and asymmetrically within the same service bay.

INTRODUCING THE **JLT3500** PROFESSIONAL LIFTS

JohnBean™

JLT3500 HYDRAULIC TWO FOR VEHICLES

KEY FEATURES

Equipped with a European made power pack which is mounted high thus offering reduced noise performance

VERSYMMETRIC®

It combines the advantages of an asymmetric and a symmetric lift and improves the ergonomics when placing the arms to lift the car.

Thanks to the Versymmetric® Technology vehicles with short (i.e. Smart) as well as long wheel base (i.e. VW T5 long) can be lifted comfortably

(For information only, please check vehicle manufacturers lifting point guide)

OPTIMUM SAFETY

Integrated CE stop makes the mechanical foot protection obsolete.

CARRIAGE AND ARMS

Very rugged design with integrated grease fitting and optimum door clearance when the car is placed on the lift.

(Picture shows lift in wide installation)

COMFORT LOWERING

Vehicle is lowered by simply pushing the lowering button. No need to activate the UP button to release the arms from the lock position.

SAFETY LOCK

Electric safety lock mechanism active during the complete lifting process is automatically released when lowering the lift thanks to the "Comfort Lowering" feature.

CONTROLS

Positioned in an ergonomic place on the primary column with clear indications of each push button.

SECONDARY CONTROL

The secondary control box is STANDARD as a promotion until March 30st, 2018

3 STAGE ARMS

Front and rear 3 stage arms always allow a perfect access to the pick up points of the vehicle.



VO-POST LIFT UP TO 3.5 T

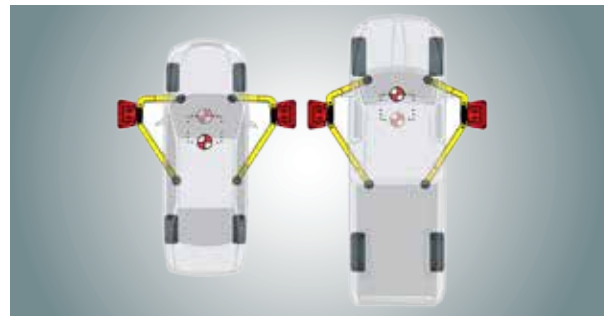

Versymmetric®

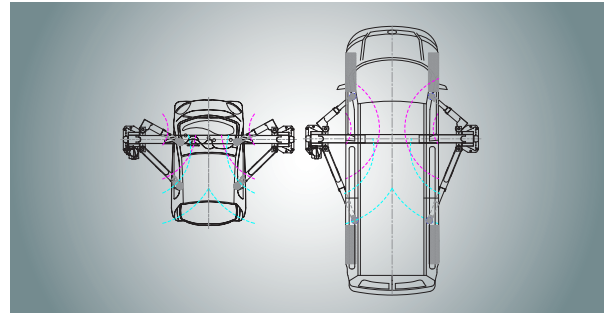

Carriage and arms

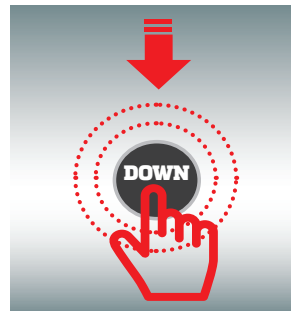

Comfort lowering



Safety lock

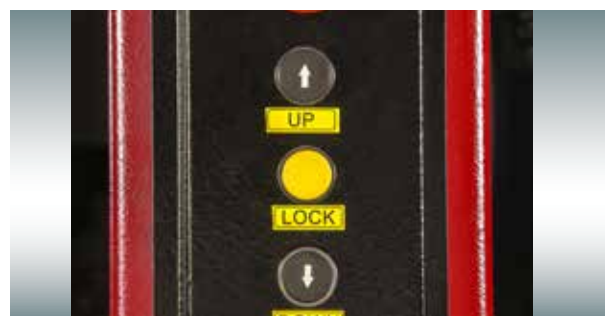

Secondary control



Controls



3 Stage arms

TECHNICAL SPECIFICATIONS

SPECIFICATIONS

Version	Standard	Tall
Lifting capacity	3.500 kg	
Lifting/ lowering times	30 / 30 sec	
Lifting height	1.965 mm	
Lowest lifting point	95 mm	
Maximum pad height from floor	140 mm	
Column height	3.856 mm	4.221 mm
Total height	3.902 mm	4.267 mm
Switch off height	3.735 mm	4.100 mm
Recommended set up width	Standard: 3.405 mm	Standard: 3.405 mm
	Wide: 3.558 mm	Wide: 3.558 mm
Drive-through width	Standard: 2.228 mm	Standard: 2.228 mm
	Wide: 2.380 mm	Wide: 2.380 mm
Distance between columns	Standard: 2.769 mm	Standard: 2.769 mm
	Wide: 2.921 mm	Wide: 2.921 mm
Long arms extraction	956 - 1.527 mm	
Short arms extraction	505 - 1.065 mm	
Power supply	400 / 50 / 16 V/Hz/A	
Motor	3 kW	
Min. necessary ceiling height	3.955 mm	4.320 mm
Weight / Shipping weight	760 / 870 kg	785 / 895 kg

OPTIONAL ACCESSORIES



Column extension kit including hoses



Optional secondary control box STANDARD as a promotion until March 30st, 2018



Holder for pick up pad adaptors



Set of anchor bolts

Storage for wheel nuts etc.

Pick up pad extension 75 mm and 150 mm

EMEA-JA

Snap-on Equipment s.r.l. · Via Prov. Carpi, 33 · 42015 Correggio (RE)
Phone: +39 0522 733-411 · Fax: +39 0522 733-479 · www.johnbean-europe.com

France

Snap-on Equipment France · ZA du Vert Galant · 15, rue de la Guivernone BP 97175 · Saint-Ouen-l'Aumône · 95056 Cergy-Pontoise CEDEX
Phone: +33 134 48 58-78 · Fax: +33 134 48 58-70 · www.johnbean-france.fr

Germany

Snap-on Equipment GmbH · Konrad-Zuse-Straße 1 · 84579 Unterneukirchen
Phone: +49 8634 622-0 · Fax: +49 8634 5501 · www.johnbean-deutschland.com

Italy

Snap-on Equipment s.r.l. · Via Prov. Carpi, 33 · 42015 Correggio (RE)
Phone: +39 0522 733-411 · Fax: +39 0522 733-410
www.johnbean-italia.com

United Kingdom

Snap-on Equipment Ltd. · Unit 17 Denney Road, King's Lynn · Norfolk PE30 4HG
Phone: +44 118 929-6811 · Fax: +44 118 966-4369
www.snapon-equipment.co.uk

Part of the machines is illustrated with optional extras which are available at extra cost. Technical modifications reserved.

JohnBean™